



LED Schutzwegebeleuchtung

Mastleuchte mit Schutzwegeoptik, 15-106W, 2200°-5700°K, IP66 / IK10, SK 1 / 2

4 Gehäusefarben, DALI-dimmbar, Nachtabsenkung, CLO, -40° - +50°C, Glasabdeckung

ZHAGA & NEMA Option, TÜV-zertifiziert, konform mit ÖN-1051, 5 Jahre Garantiedauer

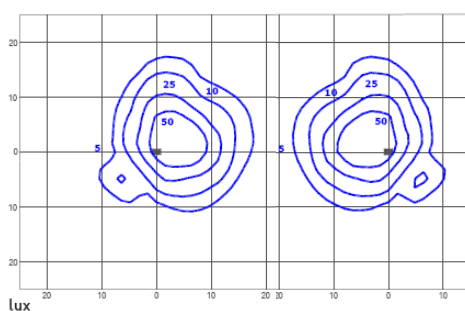

Alle Bilder: ©2021 Brenner GmbH